

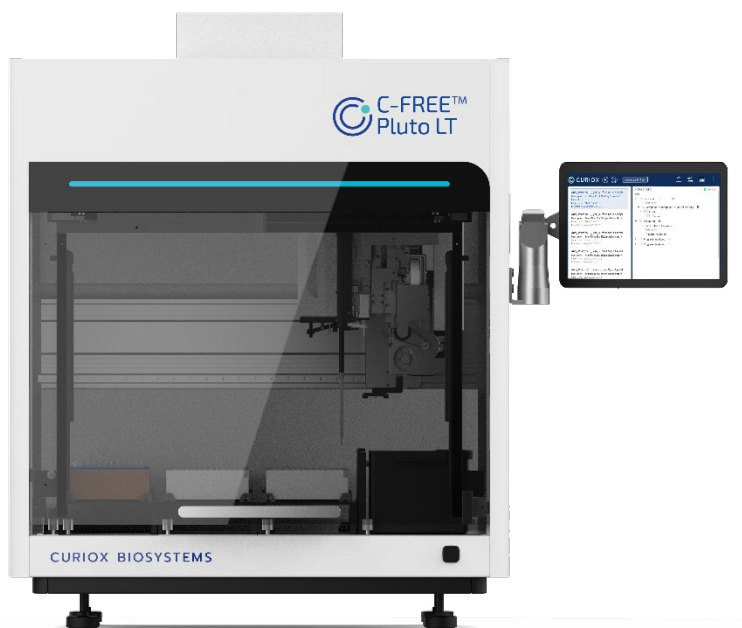

C-FREE™ Pluto LT Workstation User Manual

C-FREE™ Pluto LT Workstation [CF-PLU-LH08-01, CF-PLU-LH08A-01, and CF-PLU-LH08B-01]



While the information in this manual is considered accurate, Curiox Biosystems Pte. Ltd. disclaims all liability for errors and reserves the right to modify specifications without notice.

IMPORTANT NOTICE

Adherence to all instructions in this User Manual is crucial. Using the instrument in ways not specified by the manufacturer in this manual may damage the protection provided by the system. Non-compliance may lead to the invalidation of your service contract.

Curiox Biosystems Locations

Curiox Biosystems Co., Ltd.	Curiox Biosystems Inc.	Curiox Biosystems Pte Ltd	Curiox Biosystems China Co., Ltd
Samsung Harrington IT Tower #202, #204-213 9 Gil 41 Digital-Ro Geumchun-Gu, Seoul, 08511 ROK	400 W. Cummings Park Suite 6650 Woburn, MA 01801	2 Gambas Crescent #07-14, Nordcom II (Tower 1) Singapore 757044	Room 201-09, 2nd Floor Building 6, No. 690 Bibo Road Pudong District, Shanghai, 201203, China
Ph: +82 2 2039 7160	Ph: +1 781 214 7265	Ph: +65 6908 4201	Ph: +86 021 6838 6127
South Korea	United States	Singapore	China

Pluto LT Workstations

Part No.	Description	Details
CF-PLU-LH08-01	C-FREE Pluto LT Workstation, 8-channel	This C-FREE Pluto LT workstation comes with an 8-channel liquid handling head and is the base model with no accessories.
CF-PLU-LH08A-01	C-FREE Pluto LT Workstation, 8-channel with Gripper and Tilter	This C-FREE Pluto LT workstation comes with an 8-channel liquid handling head and is the middle model coming with the gripper and tilter accessories. It is the ideal unit for a majority of customers.
CF-PLU-LH08B-01	C-FREE Pluto LT Workstation, 8-channel with all accessories	This C-FREE Pluto LT workstation comes with an 8-channel liquid handling head and is the top model which includes all accessories [grripper, tilter, 3 temperature modules, barcode reader and the verification test kit consumable].

Contents

Chapter 1—General Information	5	Space Requirement	28
General Information	6	Working Environment	29
Introduction to the Pluto LT Workstation	7	Free Instrument Arm	30
Technical Specifications	8	Install Pipettor Modules	31
Chemical Compatibility	10	Install 8-Channel Head to Robotic Arm	31
Safety	11	Install Single Channel Head to Robotic Arm	31
User Attention Notifications	11	Software Update	31
Chemical Hazards	11	Chapter 4—Operation	32
Chemical Waste Hazards	12	Preparation for Operation	33
Material Safety Data Sheets	12	Power on Instruments	33
Instrument Safety Labels	12	Module Function Check and Verification	33
Important Safety Instructions	13	Position Calibration	33
Radio Interference	13	Run Volume Verification Protocol	33
Intended Use	13	Run Gripper Verification Protocol	33
Power and Maintenance	13	GUI Introduction	34
Installation of Correct Labware on the		Manual Settings	34
Deck	13	Worktable Viewer	34
Proper Use and Protection	13	Run Protocol Step By Step	35
Operational Safety	13	Settings	34
Chemical and Biohazard Safety	13	Import	35
Instrument Door Operation	13	Export	35
Safety Precautions	14	Data Manage	35
General Precautions	14	Module Debugging	36
Prior to System Operation	14	Fixed 8-Channel	36
CE Mark	15	Flexible Channel	36
Customer Service and Technical Support	16	Robotic Gripper Module	37
Instrument Storage and Shipping	17	Temperature Control Module	37
Chapter 2—Functional Description	18	Tilting Incubator	38
Introduction	19	Position Calibration	38
Functional Description	19	About	38
Main Components	19	Log Out	38
Safety Door	19	Operation	39
Status Light	19	Open Software	39
Touch Screen	19	User Login	39
Tip Waste Bin and Liquid Waste Trough ..	20	Instrument Initialization	39
.....	20	Prepare the Deck	41
Start/Pause Button	20	Plates and Tips	41
Hardware Interface	20	Deck Layout	42
Worktable/Deck	21	Run the Protocol	42
Integrated Modules	22	Chapter 5—Maintenance and Troubleshooting	45
Pipette Modules	22	Device Maintenance	46
Gripper Module	23	Clean After Experiment Run	46
Temperature Control Module	23	HEPA Maintenance	47
Tilter Accessory	24	Other Conditions	47
Adapters and Carriers	25	Troubleshooting	47
HEPA Module	25	An Error Occurs During Installation	47
Chapter 3—Installation	26	The Equipment Does Not Power On	47
Product Label	27	Unusual Noise Occurs During Tip Loading	47
Unboxing and Checking	27	Liquid Leaks After Aspiration Operation	47
Unboxing	27	Labware is Not Secured Properly	48
Packing List	27	An Error Occurs in CPAC	48
Placing the Instrument	28		

An Error Occurs During Protocol Operation ...	48	Appendix C: Acknowledgement of Decontamination...	58
Appendix A: Unboxing the System	49	Appendix D: Purchase Information and Feedback ..	60
Appendix B: Position Calibration	52		

Chapter 1

General Information

Chapter Overview

- General Information
- Introduction to the Pluto LT Workstation
- Chemical Compatibility
- Safety
- CE Mark
- Customer Service and Technical Support
- Instrument Storage and Shipping

General Information

This user manual provides technical guidance, installation instructions, operational procedures, and troubleshooting information for operators of the C-FREE™ Pluto LT Workstation. It covers the following areas:

- Setup and operation
- Operating principles and functional modes
- Safety features and operational precautions
- Troubleshooting and maintenance procedures

Introduction to the Pluto LT Workstation

Welcome to the C-FREE™ Pluto LT Workstation (Pluto Workstation, or Pluto LT Workstation), a state-of-the-art automated liquid handling platform designed to revolutionize sample preparation in flow cytometry and cell analysis workflows. Developed with a focus on enhancing laboratory efficiency and biosafety, the Pluto LT Workstation significantly reduces hands-on time and inter-operator variability. This introduction will guide you through the system's capabilities, design, and how it can streamline your laboratory processes, ensuring high-quality results with less manual intervention.

Distinctive Features of the Pluto LT Workstation

The Pluto LT Workstation is distinguished by several key features that set it apart in the field of automated sample preparation:

Curiox C-FREE Wash Technology: Integrating the latest advancements in cell washing, the Pluto LT Workstation employs Curiox C-FREE Wash technology, which provides gentler handling of cells compared to traditional methods. This technology ensures higher stain indexes for cleaner resolution of cell populations, crucial for precise analytical outcomes.

Compact Footprint: Designed to be accommodated in almost any lab environment, the Pluto LT Workstation boasts a compact footprint. This design consideration allows for optimal use of laboratory space without sacrificing functionality.

Standard 96-Well Plate Format: The system utilizes a standard-format 96-well plate, facilitating integration into existing workflows with minimal adaptation required. This feature ensures compatibility and ease of use, particularly for labs already using this format.

End-to-End Automation: From liquid handling to cell washing, the Pluto LT Workstation provides complete automation of the sample preparation process. This end-to-end automation minimizes the potential for human error and increases throughput, making it ideal for high-demand environments.

Enhanced Reporting and Audit Trail: Tailored to meet the needs of both clinical and research markets, the Pluto LT Workstation features advanced reporting capabilities and a robust audit trail. These features ensure compliance with regulatory standards and provide comprehensive documentation for review and analysis.

The Pluto LT Workstation is your partner in delivering efficient, reliable, and reproducible results, making it an indispensable tool for modern laboratories focused on cell analysis.

Technical Specifications

Description	Specification	
Physical (Common items)		
Dimensions (D x W x H)	740 mm x 790 mm x 895 mm; 29.1 in. x 31.1 in. x 35.2 in.	
Weight	140 kg / 309 lbs.	
Electrical		
Power Requirements	100-240VAC, 50/60Hz, 10A	
Fuse	250VAC, 10A (AC250V, T10AL, 5x20mm)	
Environmental		
Place of use	Indoor use	
Operating Temperature Range	19 - 25 °C	
Operating Humidity	20% ~ 80%, non-condensing	
Altitude	2000 m below	
Transportation and storage conditions	15 - 25 °C (0% ~ 80%)	
Mains supply voltage fluctuations	(100-240) VAC ± 10%	
Device Type	Fixed benchtop device	
Pollution Degree	Degree 2	
Operation		
Plate Type	300 µL 96 well U-bottom plates; 2.2 mL 96 well U-bottom/V-bottom deep well plates, liquid reservoirs	
Deck Capacity	15 SBS plate position	
8-Channel Pipette (9 mm fixed-pitch)		
Pipetting Principle	Air displacement	
Range of Pipetting	1~1000 µL	
Liquid Level Detection	Pressure sensing	
Pipetting Accuracy	5 µL	≤8%
	50 µL	≤2.5%
	250 µL	≤1.4%
	500 µL	≤1.5%
	1,000 µL	≤1%
Positional Accuracy	±0.1 mm X, Y, Z axes	

Description	Specification	
Single-Channel Pipette		
Pipetting Principle	Air displacement	
Range of Pipetting	1~1,000 μ L	
Liquid Level Detection	Pressure sensing	
Pipetting Accuracy	5 μ L	$\leq 8\%$
	50 μ L	$\leq 2.5\%$
	250 μ L	$\leq 1.4\%$
	500 μ L	$\leq 1.5\%$
	1,000 μ L	$\leq 1\%$
Positional Accuracy	± 0.1 mm X, Y, Z axes	
Gripper		
Force Control	1~16N	
Maximum Travel Length	92 mm	
Minimum Travel Length	74 mm	
Z-axis Travel Distance	150 mm	
Maximum Loaded Weight	$\leq 1,000$ g ≤ 2.2 lbs.	
Temperature Control Module (CPAC)		
Dimension (W \times D \times H)	140 mm \times 98 mm \times 81 mm; 5.5 in. \times 3.85 in. \times 3.19 in.	
Shell Material	HIPS	
Input Voltage	24V DC	
Wattage	120W	
Temperature Control Range	4°C ~80°C	
Heating Rate	t4 \rightarrow 21°C < 1 min., 20K/min.; t21 \rightarrow 95°C < 6.5 min., 8K/min.	
Cooling Rate	t95 \rightarrow 21°C < 5 min., 11K/min.; t21 \rightarrow 4°C < 4 min., 6K/min.	
Temperature Accuracy	$\pm 0.2^\circ$ C	
Temperature Uniformity	$\leq \pm 1^\circ$ C @4°C $\leq \pm 0.5^\circ$ C @15°C & 40°C $\leq \pm 2^\circ$ C @90°C	
Communication Interface	RS422/485	
Tilter		
Dimension (W \times D \times H)	140 mm \times 98 mm \times 70 mm; 5.5 in. \times 3.85 in. \times 2.76 in.	
Weight	1.3 kg / 2.86 lbs.	
Input Voltage	24VDC	
Wattage	60W	
Angle Control Range	0~60 degrees	
Load mass	Less than 350 grams	
Communication Interface	CAN	

Description	Specification
User Interface	
Display	10-inch touchscreen
Input control	Touchscreen interface
External Interface (Administrator-only port)	
E-Stop	E-Stop button connector
RJ45 port	Used for communication with third party device
USB port	Top: DC 5V, USB flash disk port, used for file transfer Bottom: OTG port, only used for internal debug Common: Port for administrators and engineers only
Labware	
Pipette tips	1. 250uL filter, sterilized 2. 250uL non-filter, non sterilized 3. 1000uL filter, sterilized 4. 1000uL non-filter, non sterilized
Plates	96 well, U-bottom, standard microplate, SBS format 96 well, U-bottom, deep well, SBS format 96 well, V-bottom, deep well, SBS format
Tubes	3.5mL tube Tube rack.

Chemical Compatibility

The components of the Pluto LT Workstation that come into possible contact with fluids and reagents are made from materials chosen for their resistance to common chemicals. However, certain disinfectants should not be used for decontamination. Table 1-1 on page 4 details the material composition of these components and identifies compatible reagents. Note that some reagents are incompatible with these materials and their prolonged contact should be avoided to prevent corrosion and damage.

Chemical compatibility between the component materials and accessories in the Pluto Workstation, including common reagents and disinfectants. (Adapted from: CP LabSafety www.calpaclab.com, US Plastic www.usplastic.com/catalog/files/charts/Tygon%20CC.pdf accessed Jan 2023.)

Component	Material	Approved Chemicals	Incompatible Chemicals
Deck, Tip Slide Plate, Suction Pipe, Waste Liquid Tube	Stainless Steel (304)	Ethanol, Benzene, Chloroform, Acetaldehyde, Propylene Glycol, Isopropanol, Formaldehyde, Phenol, Grease, Potassium Permanganate, Hydrogen Peroxide	Hypochlorite bleach, sulfuric acid
Waste Liquid Reservoir	Teflon	Hydrochloric acid (HCl), Sulfuric acid (H ₂ SO ₄), Nitric acid (HNO ₃), Sodium hydroxide (NaOH), Acetone Benzene	
Seal Ring	Silicon	Ethanol, isopropyl alcohol, detergents, ethylene glycol, propylene glycol, formaldehyde, formamide, sodium hypochlorite, hydrogen peroxide, sulfuric acid (<3M), ozone	Chloroform

TC-Shell	HIPS	Ethanol, Dilute acids (e.g., acetic acid), Dilute alkalis (e.g., sodium hydroxide solution), Some detergents	Strong acids (e.g., sulfuric acid), strong alkalis (e.g., concentrated sodium hydroxide), organic solvents (e.g., toluene, xylene), acetone
Syringe	Ceramic	Hydrochloric acid (HCl), Sulfuric acid (H ₂ SO ₄), Nitric acid (HNO ₃), Sodium hydroxide (NaOH), Acetone, Benzene	Hydrofluoric acid (HF), strong alkalis

Component	Material	Approved Chemicals	Incompatible Chemicals
Trash Bin, Waste Liquid Reservoir, Drive Pipe	ABS	Ethanol, Dilute acids (e.g., acetic acid), Dilute alkalis (e.g., sodium hydroxide solution), Some detergents	Acetone, Benzene, Toluene, Methylene chloride, Strong acids (e.g., sulfuric acid), Strong alkalis (e.g., concentrated sodium hydroxide)
Drive Pipe	PC	Ethanol, Dilute acids (e.g., acetic acid), chloride (NaCl) solutions, Sodium hydroxide (NaOH) (dilute)	Acetone, benzene, toluene, methylene chloride, concentrated sulfuric acid, ammonia
Carriers	6061-T6 Aluminum	Ethanol, Benzene, Propylene Glycol, Isopropanol, Formaldehyde, Ozone, Grease, Phenol, Hydrogen Peroxide	Hypochlorite bleach, soap solutions, sulfuric acid, potassium permanganate, phosphoric acid

Safety

User Attention Notifications

This manual uses several user attention phrases, each designed to draw a specific level of attention:

NOTE: Provides useful information.

IMPORTANT: Highlights information essential for proper operation of the instrument.

CAUTION: Alerts users to potential hazards that could cause injury or damage to the instrument if ignored.

!WARNING!: Indicates a serious risk of physical injury if precautions are not followed.

Chemical Hazards

!WARNING! CHEMICAL HAZARD: Handle with care. Exposure to chemicals used in this process can cause serious injury or illness.

Understand Safety Data: Before storing, handling, or using chemicals, thoroughly read and understand the Material Safety Data Sheets (MSDSs) provided by the chemical manufacturer.

Minimize Exposure: Avoid direct contact and inhalation of chemicals. Always wear appropriate personal protective equipment such as safety glasses, gloves, and protective clothing. Refer to the MSDS for more safety guidelines.

Seal Containers: Ensure all chemical containers remain tightly closed when not in use.

Monitor for Leaks: Regularly check for chemical leaks or spills and promptly follow the manufacturer's recommended cleanup procedures listed on the MSDS if an incident occurs.

Follow Legal Requirements: Adhere to all applicable local, state, provincial, or national regulations concerning the storage, handling, and disposal of chemicals.

Chemical Waste Hazards

Review Safety Data: Ensure you read and comprehend the Material Safety Data Sheets (MSDS) from the chemical manufacturers before storing, handling, or disposing of chemical waste.

Protective Measures: Minimize contact with chemical waste. Always wear suitable personal protective equipment, such as safety glasses, gloves, and protective clothing, when handling chemicals.

Cautious Handling: Exercise caution when emptying waste bottles.

Proper Disposal: Dispose of the contents of waste bottles following good laboratory practices and in compliance with local, state/provincial, or national environmental and health regulations.

Material Safety Data Sheets



Chemicals used with the Pluto LT Workstation may be hazardous. Warning labels are affixed to all chemical containers to identify potential risks.



Material Safety Data Sheets (MSDS) offer essential safety information for the storage, handling, transportation, and disposal of chemicals. It is advisable to periodically update your laboratory's MSDS records.

For Material Safety Data Sheets for Curiox reagents, please contact us at 650-226-8420 (US) or +65 6507 0361 (international). Alternatively, you can contact the chemical manufacturer directly or visit their website for more information.

Instrument Safety Labels

A safety label with a safety alert symbol is affixed to the Pluto LT Workstation to warn users of potential safety hazards. This symbol is universally recognized and prompts users to exercise caution when operating the equipment.

Symbol	Description
	Warning. Risk of personal injury to the operator or a safety hazard to the instrument or surrounding area.
	Warning. Hot surface. Burn hazard.

	Warning. Pinch point hazard.
	Danger. Hazardous voltage. Risk of electrical shock.

Important Safety Instructions

Modification Warning

Changes or modifications to this unit not expressly approved by the party responsible for compliance could void the user's authority to operate the equipment.

Radio Interference

This equipment has been designed and tested to CISPR 11 Class A. It may cause radio interference; in which case you may need to take measures to mitigate the interference. Do not use this device in proximity to sources of strong electromagnetic radiation (e.g., unshielded intentional RF sources), as these may interfere with proper operation.

Intended Use:

Do not use this instrument for anything other than its designed purpose as an automated liquid handling system that facilitates antibody cocktailing, cell washing and staining.

Power and Maintenance:

Always disconnect the power to the instrument before cleaning or performing routine maintenance.

Do not disassemble the unit.

Install Correct Modules and Accessories on the Deck:

Ensure temperature control module(s) and tilter have been placed in their correct positions and orientation and are connected correctly accordingly to the End User's deck layout/workflow requirement. Failure to do so may result in damage to the instrument. Use only Curiox-supplied modules and accessories.

Install Correct Labware on the Deck:

Ensure plates, tube rack(s), and pipette tips boxes have been securely placed at their correct positions and orientation accordingly to the required workflow. Failure to do so may result in damage to the instrument. Use only Curiox branded and supplied plates, tube racks, and pipette tips. Do not reuse plates, tubes, and pipette tips.

Proper Use and Protection:

If the equipment is used in a manner other than that specified by Curiox, the protection provided by the equipment may be impaired.

Operational Safety:

Keep hands clear of the instrument platform as it moves in and out of the instrument. To avoid muscle strain or back injury, use lifting aids and proper lifting techniques when removing or replacing the instrument.

Chemical and Biohazard Safety:



Equipment can be hazardous due to the use of chemical and biohazardous substances. This instrument can be used with potentially biohazardous materials. Use appropriate personal protective equipment (gloves, safety goggles, lab coat, etc.) for handling and disposing of biohazardous materials.

Instrument Door Operation:

Avoid opening the door while the equipment is in operation. If the door is opened, the equipment will stop. Ensure the equipment has completely stopped before proceeding.

Disposal:

Follow End-User's institutional Standard Operating Procedure (SOP) for decommissioning and disposal of laboratory instrument and accessories.

Follow End-User's institutional SOP(s) for safe disposal of used labware including pipette tips, plates and tubes.

Safety Precautions

Always keep the area around the power supply dry to avoid any potential hazards.

During operation, refrain from touching the instrument, except when interacting with the display panel.

If an unexpected error occurs, reset the Pluto LT Workstation by switching the power off and then back on.

General Precautions

- Only use the specified Curiox supplied 96-well standard or deep-well plates with the Pluto LT Workstation.
- Only use the power cord supplied with the unit for electrical supply.
- Power cord should only be connected to a grounded outlet.
- Avoid spilling liquids inside of the instrument.
- Conduct a cleaning cycle using the appropriate solution after each experiment.
- Retain the original packaging material for potential future shipping needs.
- Do not open or remove the instrument casing or motor parts; this can void the warranty and calibration and may cause irreversible damage.
- For any service needs, contact your Field Support time via curiox.com/contact-us.

Prior to System Operation

Ensure that all users of the Pluto LT Workstation have:

- Received training in general laboratory safety practices.
- Been instructed on specific safety protocols for operating this instrument.
- Been trained in handling biohazards if biohazardous materials are to be used with the system.
- Read and understood all relevant Material Safety Data Sheets (MSDS).

CAUTION Avoid operating the Pluto LT Workstation in ways not specified by Curiox. Although the system is designed to protect users, this protection can be compromised if the instrument is used improperly.

CE Mark

Based on the testing described below and information contained herein, this instrument bears the CE mark.

Directive 2014/30/EU Electromagnetic Compatibility

This device has been type-tested by an independent, accredited testing laboratory and found to meet the requirements of EN 61326-1 for Emissions and Immunity.

Verification of compliance was conducted to the limits and methods of the following:

- EN 61326-1: 2021 Emissions
- Harmonics Current Emission (Class A)
- Voltage Fluctuation/ Flicker
- Conducted Emission (Group 1 Class A)
- Radiated Emission (Electric Field) (Group 1 Class A)
- EN 61326-1: 2013 Immunity
- Electrostatic Discharge Immunity
- RF Radiated Immunity
- Electrical Fast Transient/ Burst Immunity
- Voltage Surge Immunity
- Conducted Disturbance Immunity
- Voltage Dips & Interruptions Immunity

Directive 2014/35/EU Low –Voltage Device

This device has been verified and found to meet the requirements of Directive 2014/35/EU “electrical electronic equipment designed for use within certain voltage limits”.

Directive 2015/836/EU Restriction On the use of Hazardous Substances (ROHS 3)

This device has been verified and found to meet the requirements of Directive 2015/836/EU “restriction on the use of certain hazardous substances in electrical and electronic equipment”.

Directive 2012/19/EU Waste Electrical and Electronic Equipment (WEEE)

Dispose of the device according to Directive 2012/19/EU, on “waste electrical and electronic equipment (WEEE)” or local ordinances.

Customer Service and Technical Support

Website (Worldwide): www.curiox.com

(China): www.curioxbio.cn

United States

Tel +1 650 226 8420

Fax +1 650 590 5406

E-mail sales@curiox.com

Address:

Curiox Biosystems, Inc.
400 West Cummings Park
Suite 6650
Woburn, MA 01801

Singapore

Tel +65 6908 4201

Fax +65 6908 4203

E-mail sales@curiox.com

Address:

Curiox Biosystems Pte. Ltd.
2 Gambas Crescent
#07-14 Nordcom II (Tower 1)
Singapore 757044

China P.R.

Tel +86 21 68386127

E-mail sales-china@curiox.com

Address:

Curiox Biosystems China Co., Ltd
203A, BD 2, Micro Electron Port
690 Bibo Road, Zhangjiang
Pudong District, Shanghai, 201203

South Korea

Tel +82 2 2039 7160

E-mail sales@curiox.com

Address:

Samsung Harrington IT Tower
#202, #204-213
9 Gil 41 Digital-ro
Geumcheon-gu, Seoul 08511

Instrument Storage and Shipping

Before transportation, disinfect the equipment by wiping it with 75% ethanol. For long-distance transportation, ensure that moving parts are secured and packed in shock-proof packaging. Retain the original packing material for future transportation needs.

For transportation and moving of equipment, please contact the Curiox technical support team. The instrument is quite heavy; it is recommended that at least four adult males carry it or use a forklift with a load capacity of at least 400 kg.

Stow the instruments in a regulated storage environment: Temperature: 4-28°C, Humidity <80% RH, non-condensing.

The equipment must be transported in its original packaged state, kept upright, and protected from tumbling and rain. Do not unpack the equipment without Curiox personnel present and be sure to handle it with care during transportation.

Do not touch moving parts.

CAUTION Prevent serious personal injury: Do not put your hand into equipment gaps.

Do not move the device without the manufacturer's consent.

Chapter 2

Functional Description

Chapter Overview

- Introduction
- Functional Description

Introduction

This chapter provides a detailed overview of the Pluto LT Workstation components.

Functional Description

The main components of the Pluto LT Workstation are shown below.

Main Components

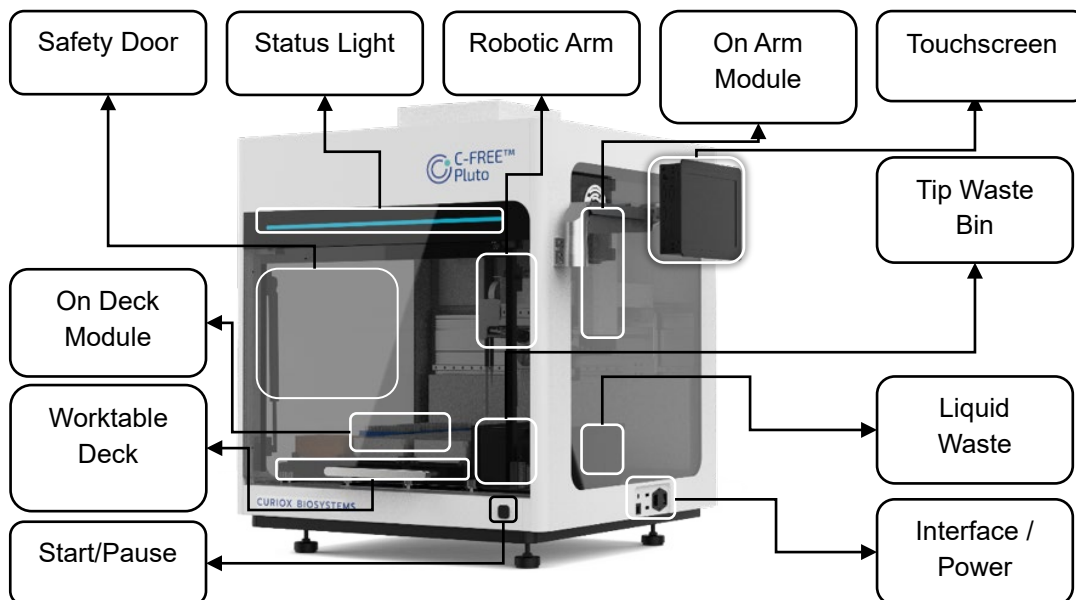

Safety Door

To ensure the safety of the operators, the Pluto LT Workstation can sense the status of the safety door. Once the door is opened during the run, the system will automatically pause until the door is closed again.

Status Light

The status light will be turned on and stay blue when the instrument is powered on.

Touch Screen

The Pluto LT Workstation is equipped with a 10-inch LED touchscreen and an adjustable arm support. The arm can rotate 180 degrees forward and backward, and 90 degrees up and down, as shown below.

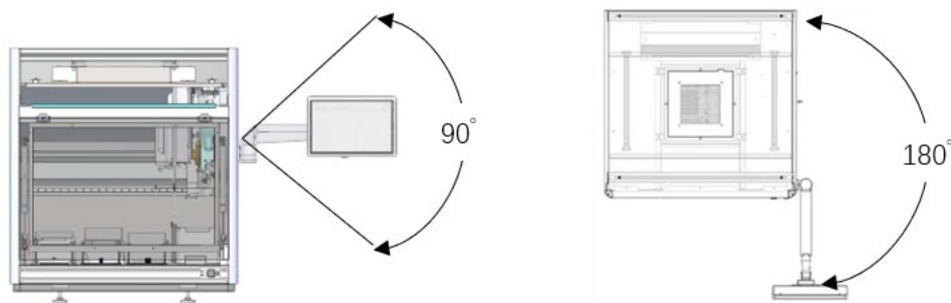

Tip Waste Bin and Liquid Waste Trough

The tip waste bin and liquid waste trough are used to collect solid and liquid waste generated during the experimental run.

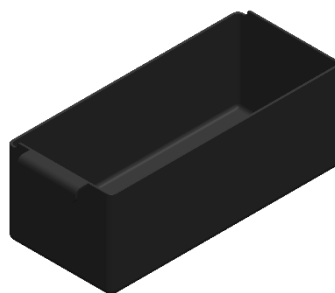
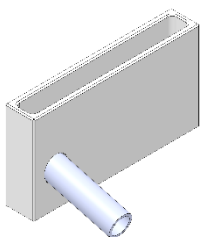

Start/Pause Button

Automatic Switching

- Switches on when you start the runner application.
- Switches off when you close the application.

Status Indication

- Stays green when the application is in operation.
- Flashes when the application is on standby.

Hardware Interface

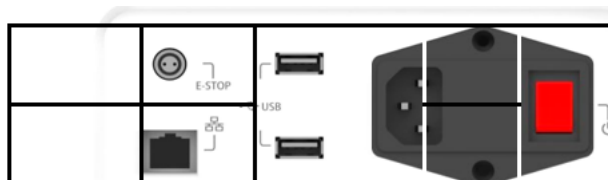

- E-STOP: E-Stop button connector [an administrator-only port]
- RJ45: used for communication with third party device [an administrator-only port]
- USB port (top): DC 5V, USB flash disk port, used for file transfer [an administrator-only port]

- USB (bottom): OTG port, only used for internal debug [an administrator-only port]
- Power connector: Connect to power cable, AC100-250V 10A
- Fuse connector: F10AL250V, (Notice: if the fuses are damaged, only replace with ones specified by Curiox)
- Power Switch: turns power on or off.

Worktable/Deck

The Pluto LT Workstation supports up to 16 SBS plate position on the deck as shown below.

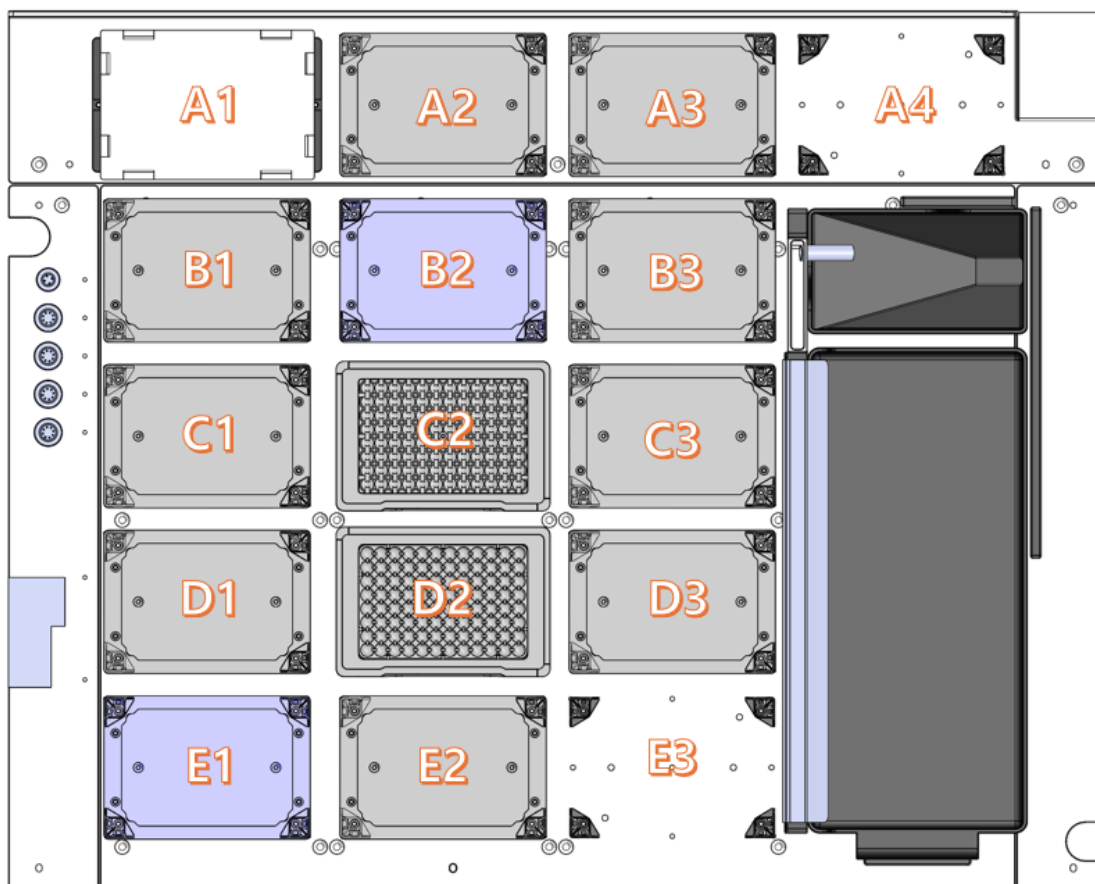

Note The A4 position is only reachable by the Gripper accessory

Integrated Modules

	Parts name	Type
Pipette Module	8-Channel	F8M
	Single-Channel	SPM
Gripper Module	Left/Right	RGM
MSCH Module	Temperature control module	MT-120
Other	HEPA Filter	Positive pressure
		Negative pressure

Pipette Modules

The Pluto LT Workstation is equipped with a fixed 8-channel pipette and a single channel pipette.

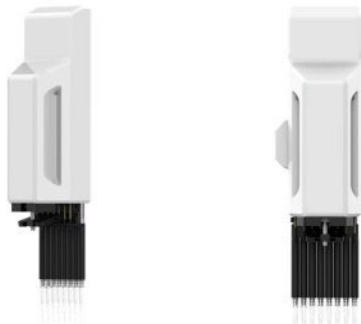
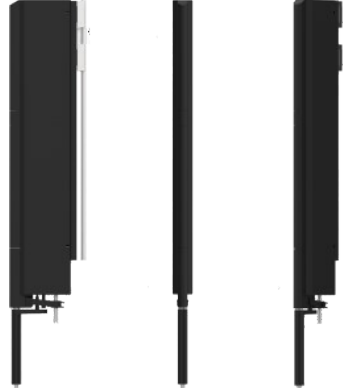
Specification	8-Channel Pipette	Single-Channel Pipette
		
Size/Dimension	9 mm fixed-pitch	Individual Z-axis 18 mm distance flexible channel pipette module
Partial Loading Support	Yes	No
Rapid Replacement Support	Yes	
Consumables and Adapters	Compatible with all kinds of SBS/SLAS standard-pitch consumables, module adapters	
Pipetting Principle	Air displacement	
Range of Pipetting	1-1,000 μ L	
Liquid Level Detection	Pressure sensing (pLLD)	

Specification	
Pipetting Accuracy	$\leq 8\%$ @ 5 μL $\leq 2.5\%$ @ 50 μL $\leq 1.4\%$ @ 250 μL $\leq 1.5\%$ @ 500 μL $\leq 1\%$ @ 1,000 μL
Positional Accuracy	± 0.1 mm X, Y, Z axes

Gripper Module

The gripper module can move different consumables on the deck, the fingers direction can mount towards left or right.



	Parameters
Force control	1-16 N
Maximum travel length Lmax	92 mm
Minimum travel length Lmin	74 mm
Z-axis travel distance	150 mm
Maximum loaded weight	$\leq 1,000$ g

Temperature Control Module

The CPAC module is capable of heating, cooling liquids in a plate, and provide different temperature conditions during experimental tests for reagents on deck.

Different consumables can be matched by adapters.



	MT-120
Dimension (D × W × H)	98 mm x 140 mm x 81 mm

	3.9 in. x 5.5 in. x 3.2 in.
Shell Material	HIPS
Input Voltage	24V DC
Wattage	120W
Temperature Control Range	0°C- 120°C
Heating Rate	$t_{4 \rightarrow 21^{\circ}\text{C}} < 1 \text{ min.}, 20\text{K/min.}$ $t_{21 \rightarrow 95^{\circ}\text{C}} < 6.5 \text{ min.}, 8\text{K/min.}$
Cooling Rate	$t_{95 \rightarrow 21^{\circ}\text{C}} < 5 \text{ min.}, 11\text{K/min.}$ $t_{21 \rightarrow 4^{\circ}\text{C}} < 4 \text{ min.}, 6\text{K/min.}$
Temperature Accuracy	$\pm 0.2^{\circ}\text{C}$
Temperature Uniformity	$\leq \pm 1^{\circ}\text{C}@4^{\circ}\text{C}$ $\leq \pm 0.5^{\circ}\text{C}@15^{\circ}\text{C}\&40^{\circ}\text{C}$ $\leq \pm 2^{\circ}\text{C}@90^{\circ}\text{C}$
Communication Interface	RS422/485
Adapter	For consumable fixing, see adapter list



CAUTION: Hot Surface. Avoid contacting the CPAC after use to prevent burns.

Tilter Accessory

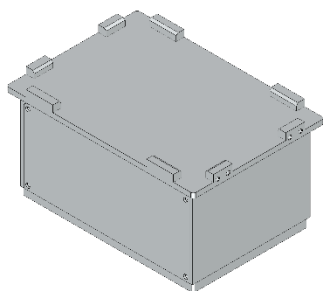
The tilter used with the Pluto LT Workstation is an optional component designed for accelerated sample settling.

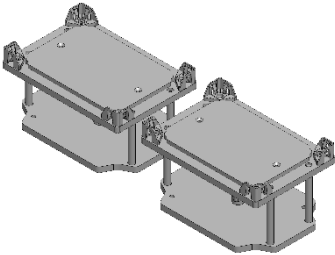

Adapters and Carriers

	Image	Description
Deep Well Plate Adapter		96-well deep well U-bottom plate 2.0 mL Deep Well Plate;
Micro Plate Adapter		96-well microplate with round and U-bottom
57 mm/62 mm Carrier		SBS/SLAS standard pitch consumables

HEPA Module

Perform air filtration to ensure air cleanliness during operation.

Protection Level	H13
Wind	150m ³ /h
Wind Speed	0.4m/s±20%
Wind Pressure	80-100Pa
Noise	< 65dB(A)
Specifications	Positive pressure / negative pressure optional
Lifetime (recommended)	HEPA: 8-10 months in ordinary environment; 12 months in clean environment

Chapter 3







Installation

Chapter Overview

- Product Label
- Unboxing and Checking
- Placing the Instrument
- Free Instrument Arm
- Install Pipettor Modules
- Software Update

Product Label

The product labels can be found on the exterior or interior of the product and provide basic information about the product.

	Manufacturers
	Production date
	Validity period
	Serial number
	Check the instructions
	General warning signs
	Electronic device disposal

Unboxing and Checking

Unboxing

Please follow the instructions in Appendix A for unboxing the Pluto LT Workstation.

Packing List

After unboxing, please check all the instruments and accessories in the list below. To prevent damage, some of the parts may be packaged individually inside of the crate. Please ensure that all the materials are matched to the packing list. If any items are damaged or missing, please contact the manufacturer or dealer, and be sure to retain the original packaging materials.

Please refer to the document titled 'IN-PT-RD-FORM-2-Pluto System Packaging List' for more details.

Getting Started

For a step-by-step guide to setting up the product, refer to the Quick Start Guide document

Placing the Instrument

The instrument is a fixed benchtop system. Ensure the work area is well-ventilated, and does not contain corrosive or flammable gases, or strong magnetic interference. Confirmed that the instrument placement allows for the power switch to be easily accessible.

Note

- Do not install the instrument on a combustible surface.
- Do not place the device in a position where it is difficult to turn off.
- Do not place the instrument in a wet or dusty location.
- Do not place the instrument on a cushioned or unstable surface.
- Do not place the instrument against a wall or stack other objects around/against it.
- Please use a forklift truck with load bearing 300KG or more when moving (Contact Curiox personnel before moving instrument).
- Ensure that the bench surface is level and that it can support weights up to 250 kgs.



There are moving parts inside the container. Ensure safe operating practices.

Space Requirement

Pluto LT Workstation space requirement is as depicted.

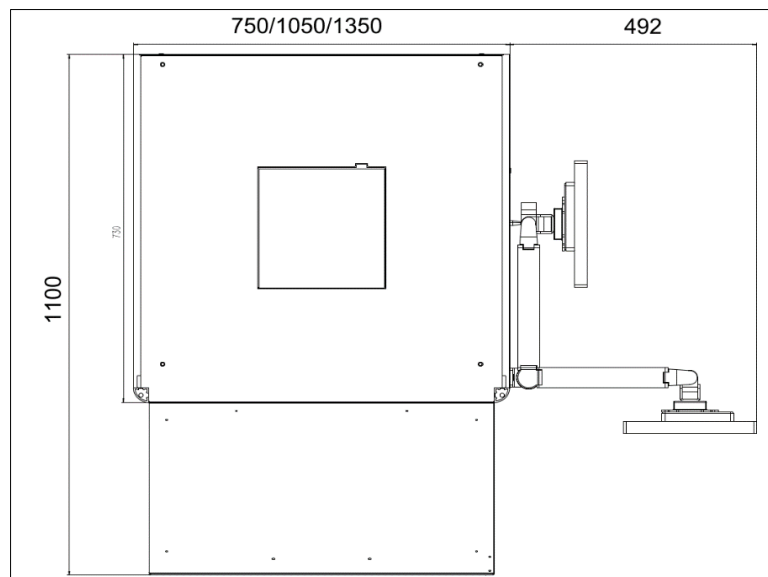

Working Environment

Working temperature	19°C-25°C
Relative Humidity	20%-80%, no condensation
Altitude	2000 m below
Barometric Pressure	80kPa-106kPa
Place of Use	Indoor use
Device Type	Fixed benchtop device

1. Remove the machine from the wooden box pallet and place it on a suitable countertop. (At least four people are required to carry the instrument safely.) Countertop should be able to hold (insert weight in kg and lbs.) plus weight of related consumables and accessories.

Make sure to remove the pallet foam that is under the instrument before placing on the countertop.

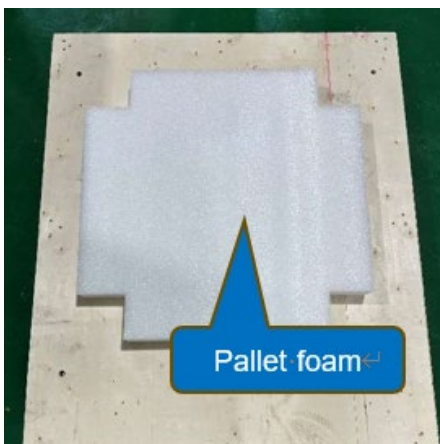
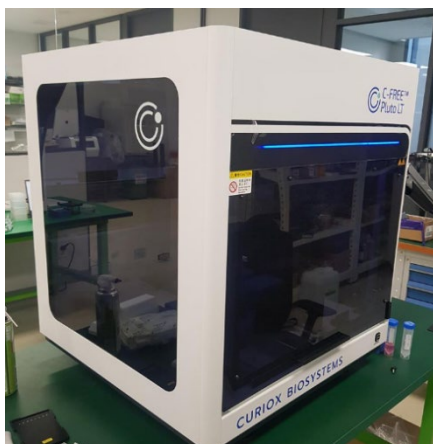

2. Remove the rear inner foam



Free Instrument Arm

1. Remove the slide clips (2 ea. on X-axis and 1 on Y-axis).
2. Open the front door of the device (from the righthand side) and observe the pipetting module position. Remove the slider by rotating the slider clip knob counterclockwise, which will loosen the slider clip.

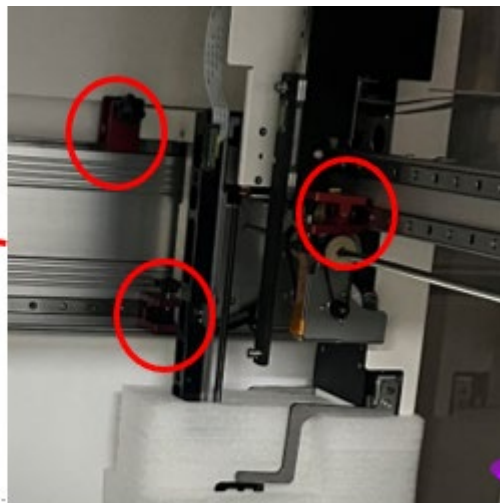

3. Remove the front inner foam.

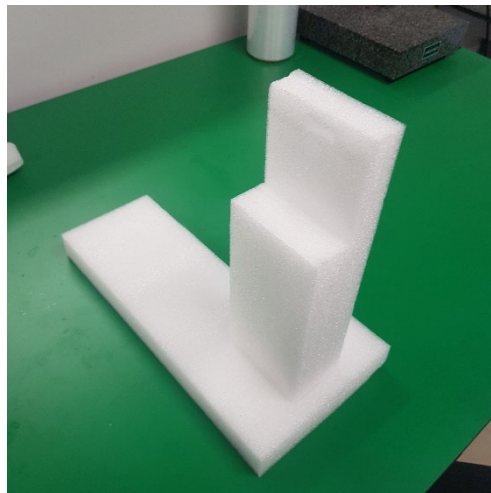

Install Pipettor Modules

Install 8-channel Head to the Robotic Arm

The 8-channel pipette module should be secured on the front sides with two M4x6 thumb screws. When securing, you can adjust the height of the 8-channel pipette using a jig.

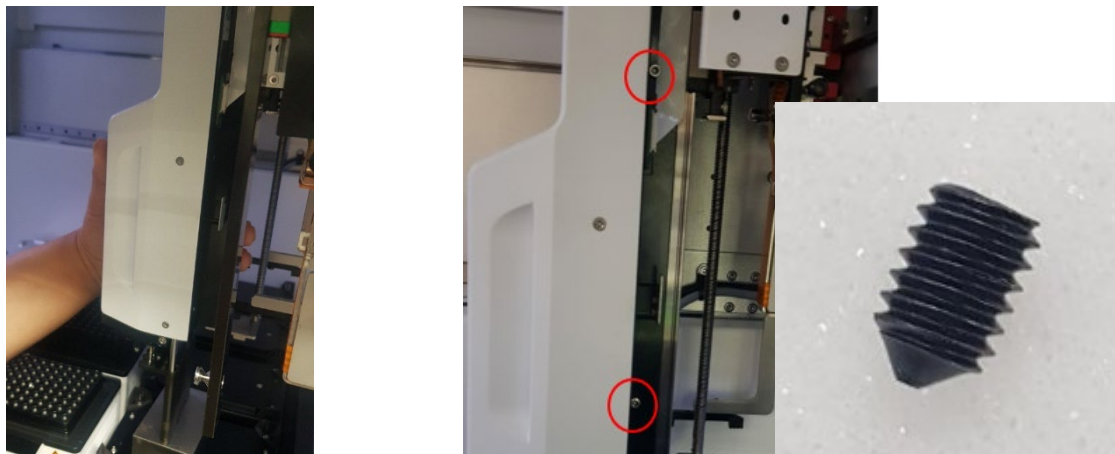

Install Single Channel Head to the Robotic Arm

The single channel pipette module should be secured on the front sides with two M4x6 thumb screws.



Software Update

Contact technical support for software updates.

Chapter 4

Operation

Chapter Overview

- Preparation for Operation
- GUI Introduction
- Operation

Preparation for Operation

Power on the Instrument

Connect the power cable and turn on the instrument.

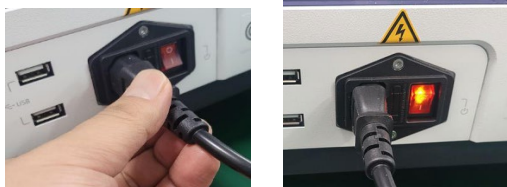

Note

- Only the power cord specified by Curiox (250V10A) can be used to connect the power supply.
- Make sure the power switch is in the off position before connecting the power supply.



Be sure that the ground wire in the power outlet is working correctly.



Do not pull the power cord when pulling out.
Do not touch the metal part of the plug.

Module Function Check and Verification

Position Calibration

Instruments are finely calibrated for position accuracy before shipping. Recalibration may be necessary during installation due to shipping and transportation movement.

Position calibration ensures accurate alignment of the dispensing head over the target wells or containers. This process involves setting reference points and adjusting the X, Y, and Z axes to guarantee precise fluid dispensing. Please refer to Appendix B for more information on position calibration.

Run Volume Verification Protocol

Please contact Curiox personnel for assistance.

Run Gripper Verification Protocol

Please contact Curiox personnel for assistance.

GUI Introduction

Manual Settings

Click the  button on the main window to access the manual settings screen (Settings for lighting, HEPA, and rank).

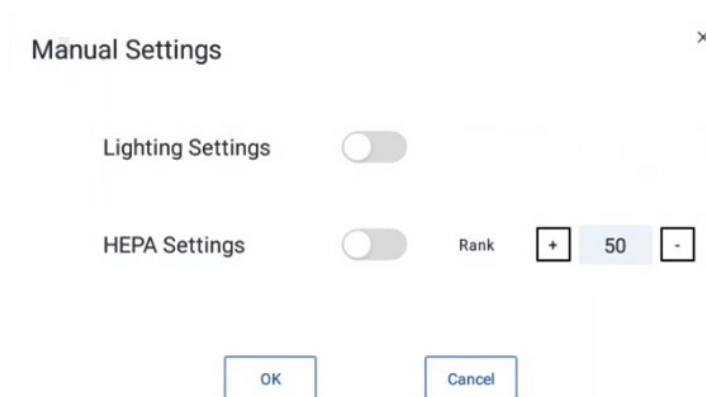

Worktable Viewer

Click  to access the worktable viewer button, which allows you to get detailed information on the consumables on the instrument deck.

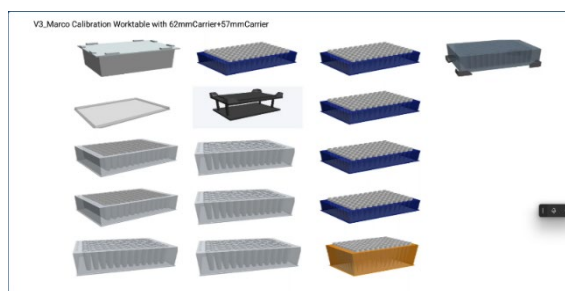

Run Protocol Step By Step

Click  button, to access protocol steps menu.

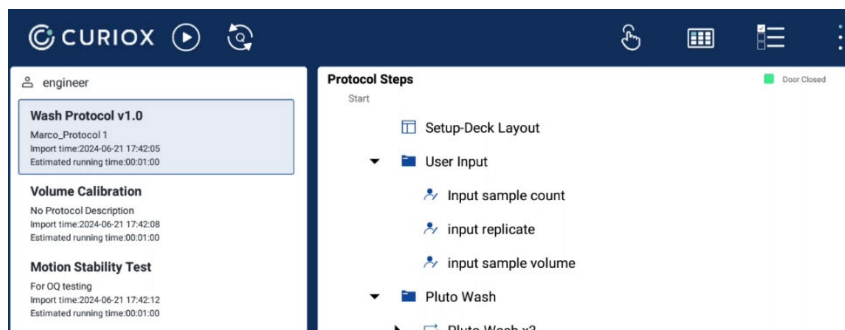

Settings

Import

Automatic import of experimental data (protocol, instrument parameters, worktable, modules, adapters, consumables, etc.)

Export

The device execution log is stored in the database. You can export this database to an SD card for analysis and backup. See the individual SOP for more information.

Data Manage

Used to export or delete protocols, worktables, instrument parameters and to edit liquid class information.

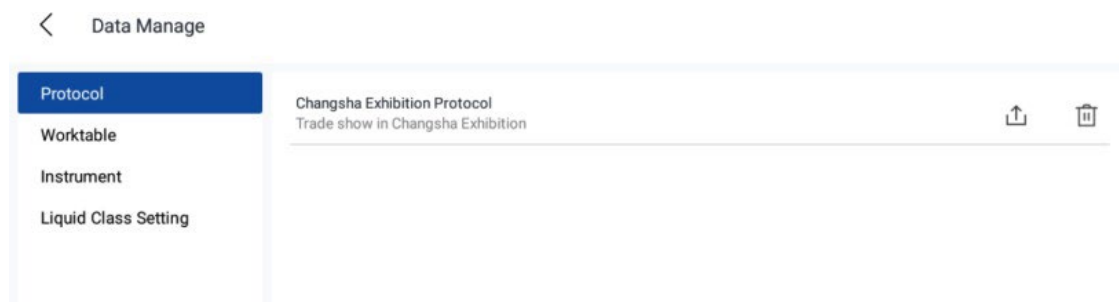

Module Debugging

Used for debugging and setting up manual control of each module.

Fixed 8-channel Pipette

Used to access the 8-channel debugger. The user chooses this command to check the current location of X/Y/Z motor, and to manually manage settings for aspirate, dispense, load/unload tips, and relative move or absolute move.

Relative move: Move distance relative to current position, increase or decrease step size to move.

Absolute move: Move distance relative to home position.



Flexible Channel

For flexible channel debugging, the user chooses this command to check the current location of X/Y/Z motor, and to manually manage settings such as aspirate, dispense, load/unload tips, and relative move or absolute move. Users also can select only one pipette move or 2 pipette synchronized movements.

Robotic Gripper Module

For gripper module debugging, users can get the current position of each motor and control motor move in X, Y, Z three directions manually.

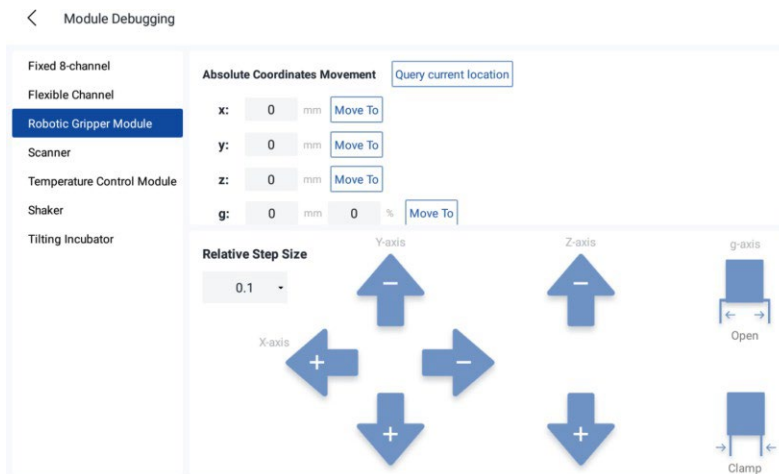

Temperature Control Module

Used for debugging temperature control functions. The user selects one module type (temperature control module, heater-shaker module or temperature control shaker module). The user can see the current temperature, set target temperature, and set temperature when the module is turned on.



Tilting Incubator

This is used to adjust the tilter device, and can control the tilter device reset, tilt angle, tilt speed, vibration time and vibration intensity parameters.

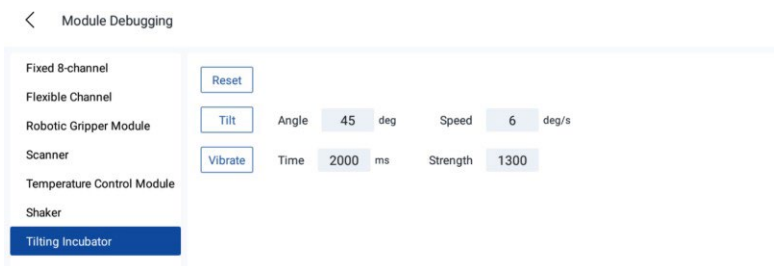

Position Calibration

Usually position calibration has been done at the factory and the user does not need to calibrate on site, if the user wants to calibrate the device, please contact the engineer to help.



About

Displays software information.

Log Out

Allows users to log out of the current account.

Operation

Please follow the instructions below to run your protocols.

Open Software

Turn on the device and confirm the workbench layout. Then click the PlutoLTStartUp software icon on the screen.



User Login

After opening this app, the user will go to the account login page. The user should select Username and enter Password. During the first login time to the app, it is necessary for the user to first import the account from the editor software. Refer to the Protocol Editor for help. The user can select their username after import account. The default password is 123456 for new users.

Once Logged in, the main window will display. the protocol list of the current user on the left side. On the right side, detailed information of each protocol is shown.

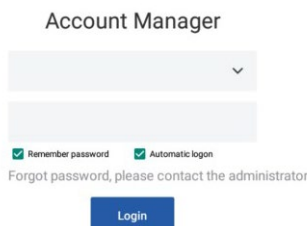

Instrument Initialization

The device needs to be initialized every time the power is turned on, the control software is restarted, or a fault is resolved.

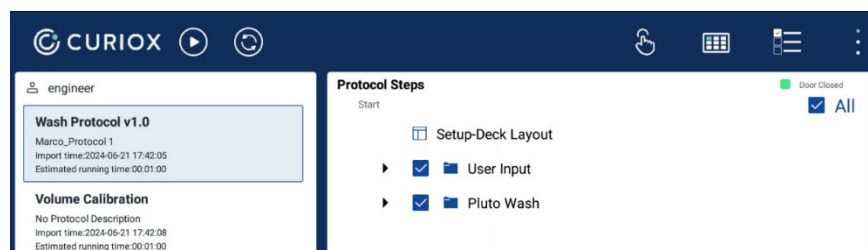

Please follow the guide,  click to initialize the device.

After the device has been initialized, the center of the screen, the user can the initialize button will be changed to  quickly.

Initialize finished.

the 'initialize finished' message will show in then move to the next operation. The icon of which can be used to initialize the device

When there is movement occurring in the device, do not touch any internal parts!

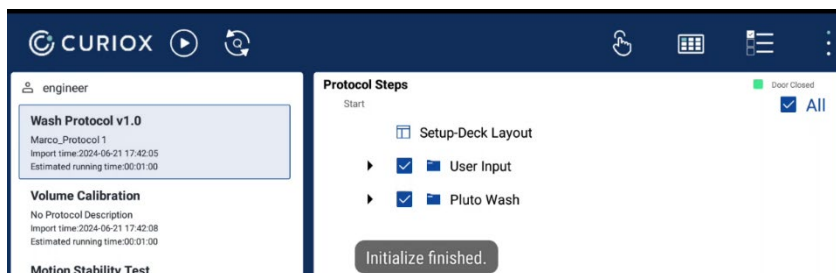

The pipettor modules will return to their home position (as shown below) when the initialization is finished.

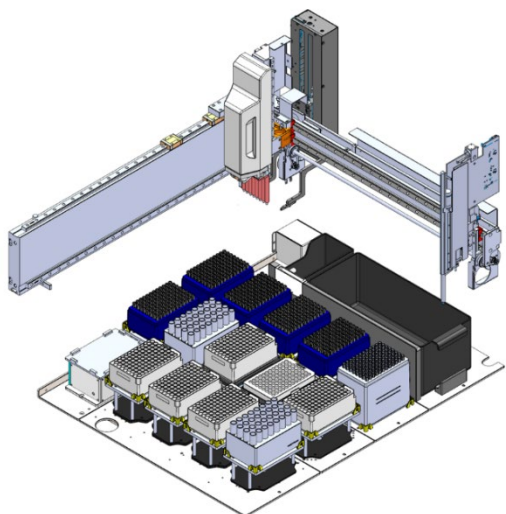

Home positions of the on-arm modules

Prepare the Deck

Plates and Tips

The Pluto LT Workstation uses three types of microplates to maximize performance during experiment runs.



Bright Red (RGB 255,0,0)
Size : 26mm X 5mm

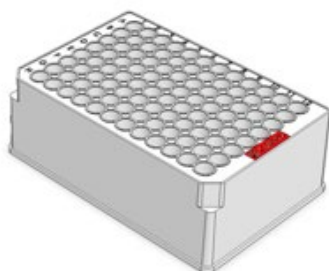

96 Deep Well U-Bottom Plate



Deep Green (RGB 0,139,0)
Size : 26mm X 5mm

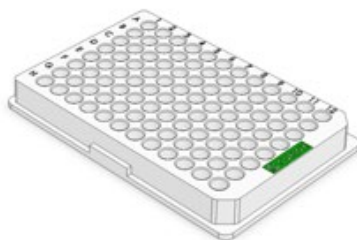

96 Well Microplate



Deep Blue (RGB 0,0,139)
Size : 26mm X 5mm

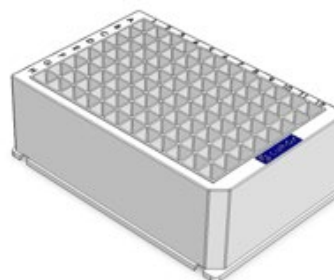

96 Deep Well V-Bottom Plate

The Pluto LT Workstation uses two types of pipette tips: 250 μ L and 1,000 μ L tips. Please fully load the tip box before placing it onto the deck. This will prevent running issues.

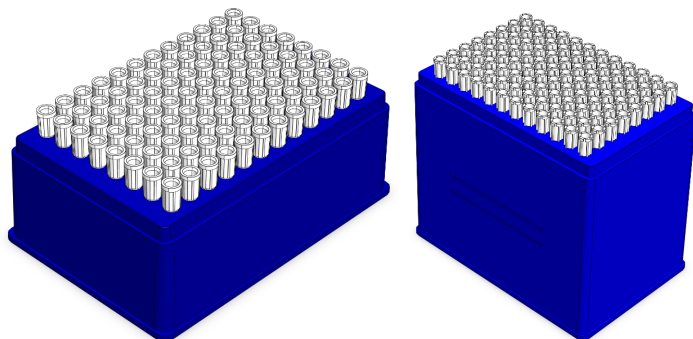

250 μ L tip box (left) and 1,000 μ L tip box (right)

Deck Layout

Each of the protocols listed in the Runner software are designed based on the system's specific deck layout. Check the deck layout and prepare the deck before each run.

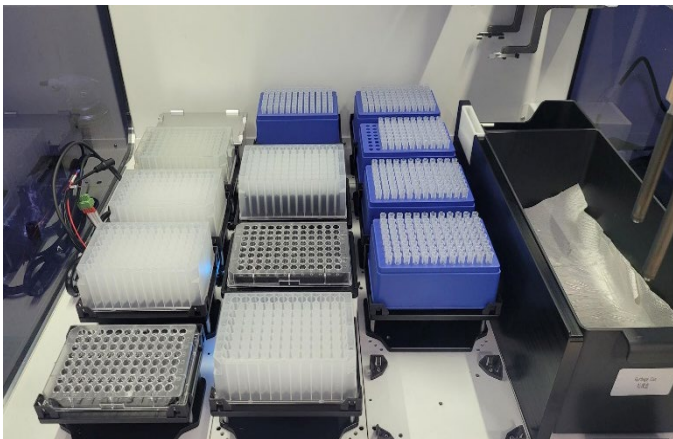

Run the Protocol

Select the desired protocol.

The main steps of this protocol will be shown on the right side of the display, allowing you to review the protocol and make changes as needed.

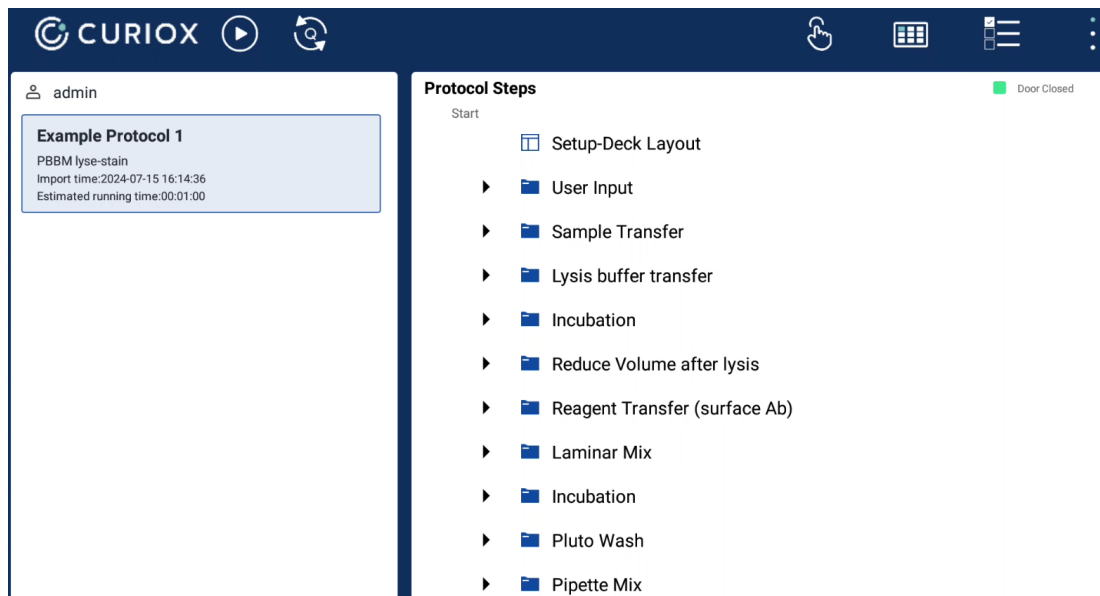

Close the safety door. Then  click the start button to begin the experiment.

Note

Please avoid slamming the safety door. If the safety door remains open, users cannot start the run. A warning message will appear.

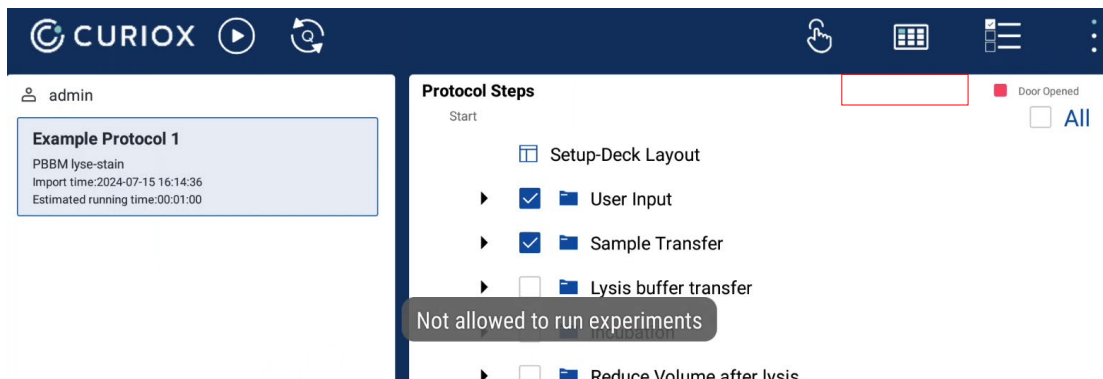

Some of the protocols may require key parameters of the experiment to be added (i.e., Sample Number, Replicate Number, Sample Volume, etc.)

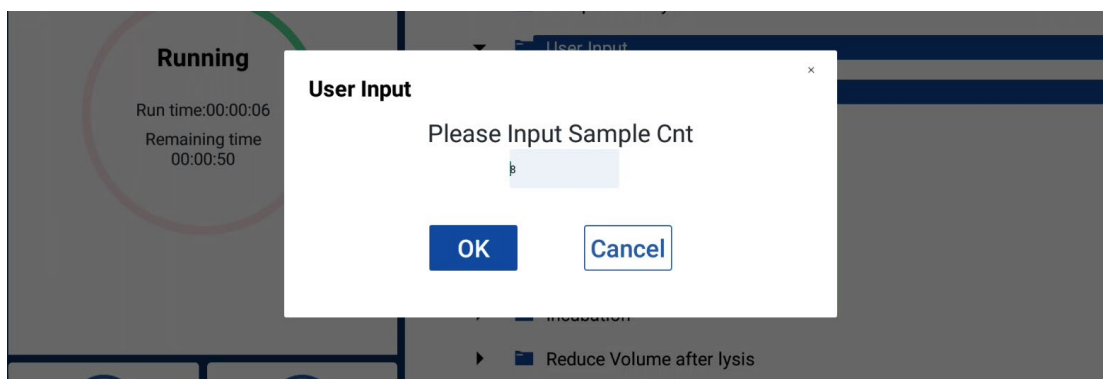

During the run, the current steps (on right) and the status info (on left) will be shown. Users can press the Pause or Stop buttons (on bottom left corner of screen) if they need to pause or abort the run.

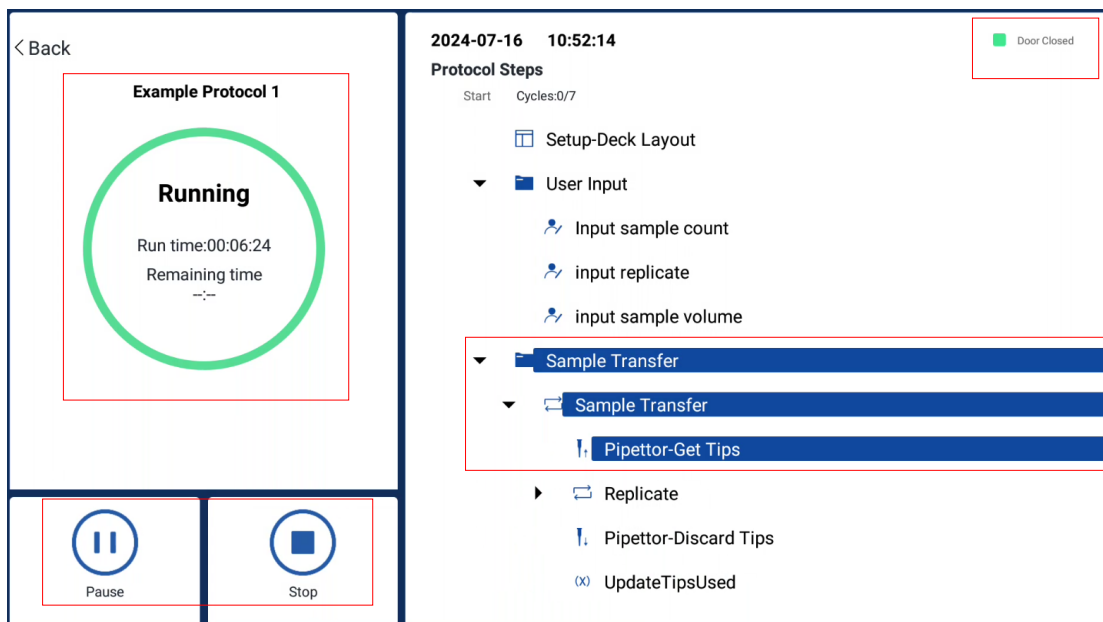

NOTE Although it is possible to pause and continue the run by directly opening/closing the safety door, Curiox does not recommend this action. Doing this may affect the experiment results.

If the run is aborted by hitting the Stop button when a tip is on the pipettor, a message will show on the screen. You can choose to eject the tip via the manual handling or the auto handling method.

!WARNING! Pausing when the pipettor is dispensing/aspirating liquid will severely affect the **ACCURACY** of your experiment and **DATA QUALITY**. Use this button with caution.

The device has detected that the [SingleChannel] pipettor has one or more tips.. Please choose the handling method:

- Manual handling: The user can go to debug page to recycle liquid.
- Auto handling: The device will automatically dispense liquid to the liquid trash and then discard the tip into the trash.

Manual handling

Auto handling

When the run is completed, you can hit the back button on the top left corner of the screen and go back to the main window of the Runner app.

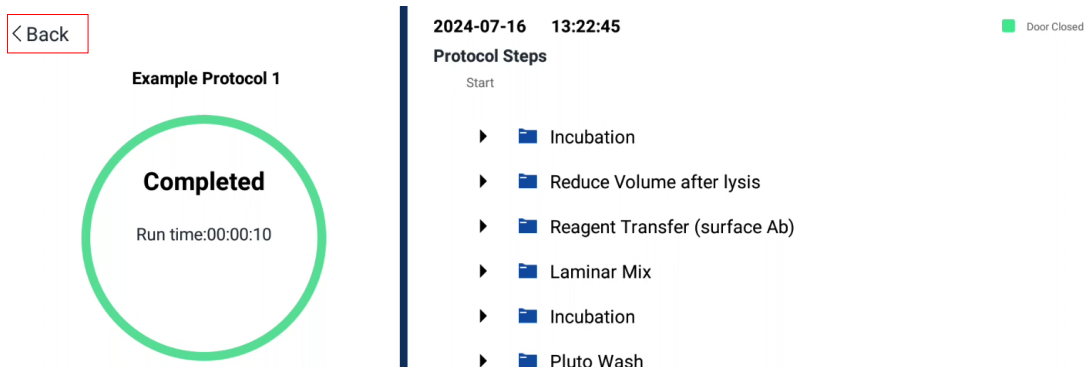

Chapter 5

Maintenance and Troubleshooting

Chapter Overview

- Device Maintenance
- Troubleshooting

Device Maintenance

Clean After Experiment Run

After each run, following these steps will ensure that the instrument is properly maintained and ready for the next run.

Power Off and Access

Turn off the power switch and open the front door.

Remove Labware

Remove all labware after the run. Leaving labware with any chemical reagents may result in damage to the system.

Empty the Waste Bin

Empty the waste bin(s) after each run and wash with DI water and 75% ethanol.

Ethanol Disinfection

If necessary, use a 75% alcohol solution to wipe the surface of the instrument and function modules 2-3 times.

Nucleic Acid Removal

If needed, use a nucleic acid scavenger to moisten a clean paper towel and wipe the surface of the instrument and function modules 2-3 times.

Water Cleaning

If necessary, use DI water to moisten a dust-free paper towel and wipe the surface of the instrument and function modules 2-3 times.

Drying

1. After wiping, allow the instrument to dry naturally.
2. Once the instrument is dry, close the front door.

HEPA Maintenance

Under normal usage conditions, the primary filter of the air filtration system is effective for 3 months. It is recommended to replace the filter every 3 months. The high-efficiency filter has a validity period of 12 months, with a recommended replacement interval of 12 months. The filters should only be replaced by Curiox authorized technical support personnel.

Other Conditions

Prior to disposal, use 75% ethanol to clean and disinfect the equipment.

Troubleshooting

Common faults and possible solutions are listed in this section. If you encounter any issues not mentioned in this manual, please contact Curiox technical support.

An Error Occurs During Initialization

- Turn the power off and on again and then reinitialize.
- If an error related to CPAC or Tilter occurs, contact the Curiox service team for assistance.
- Manually turn the screw on the ejector up and then try initializing again.

The Equipment Does Not Power On

- Confirm that the power cord is properly connected.
- Check the fuse condition as unstable AC power may cause the fuse to blow, preventing the equipment from powering on

Unusual Noise Occurs During Tip Loading

- Recalibrate the position of the tip(s).
- Check if the O-ring is worn out.

Liquid Leaks After the Aspiration Operation

- Check if the O-ring is worn out.
- Try replacing the tip(s) and attempt again.

Labware Is Not Secured Properly

- Check if the plate holding bracket is damaged. If it is damaged, replacement is necessary.

An Error Occurs In CPAC

- If condensation has caused water to accumulate on the CPAC surface, remove the water and dry thoroughly before running it again.

An Error Occurs During Protocol Operation

- Take a photo of the error code and send it to the Curiox service team. We will provide feedback as soon as possible.

Appendix A: Unboxing The System

Curiox ships your Pluto LT Workstation in a sturdy plywood crate. The shipping crate uses hooks and latch clamps to secure the top, side, and bottom panels together. Using latches, instead of nails or screws, means you won't need a crowbar (or a lot of force) to disassemble the crate, and you can reassemble it later if needed.

To release the latches, flip the latch tab up and turn it to the left (counterclockwise). This action moves the clamp arm out of its corresponding retaining bracket. You can then flip the latch arm away from the crate.

Caution Crate edges can get roughed up during shipping. Wear work gloves to protect your hands from wood splinters.

1. Cut the cable ties and unlock the eight latches holding the top to the sides.

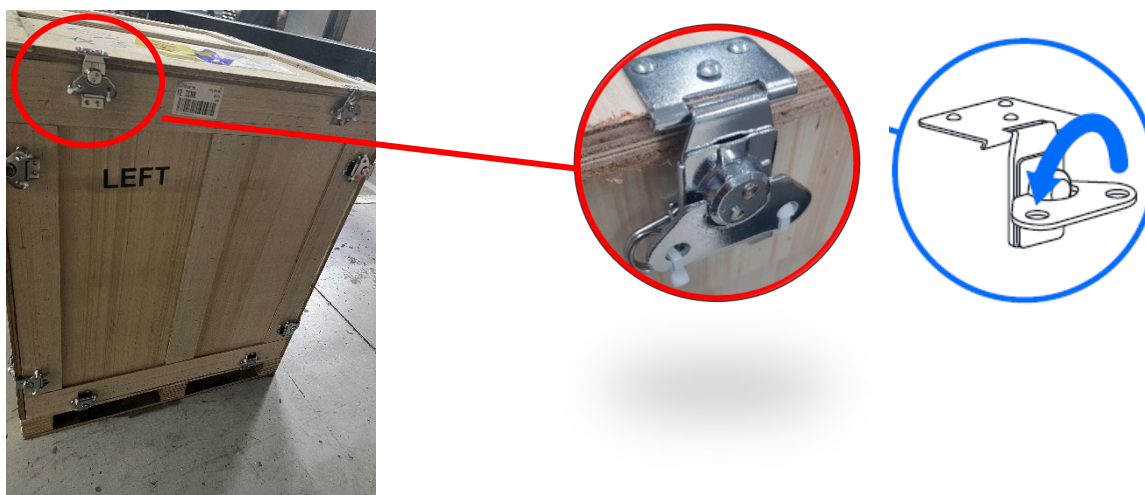

2. After releasing the latches, remove the top panel and the four-side panels.



3. Cut the clear film and remove accessory boxes and set them aside.



Accessory box, single pipette and 8-channel pipette

4. Remove the external foam from the four corners. Then remove the anchor nuts, anchor screw and anchor fixings (with spanner.)



5. Remove the screen bracket foam.



Screen bracket form



Appendix B: Position Calibration

This section explains the position calibration method.

Preparation

Prepare the tools needed:

- Calibration Fixture x 1
- Deep Well Plate x 1
- Microplate x 1
- Feeler Gauge x 1

Position Calibration

Calibration is carried out in the following sequence.

1. Select the 8-channel pipette module
2. Position alignment
3. Select Single channel pipette module
4. Position alignment
5. Select Gripper module
6. Position alignment
7. Liquid trash position alignment
8. Tip trash position alignment

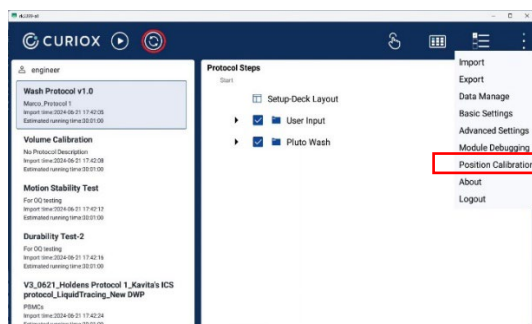

After turning on the equipment and initialization is complete, you can access the calibration menu. Be sure initialization is completed first.

Before Calibration

Before the position calibration, users need to select the worktable they want to calibrate and switch the status of the pipettors.

1. Tap the  icon and then select **Basic Settings** menu.

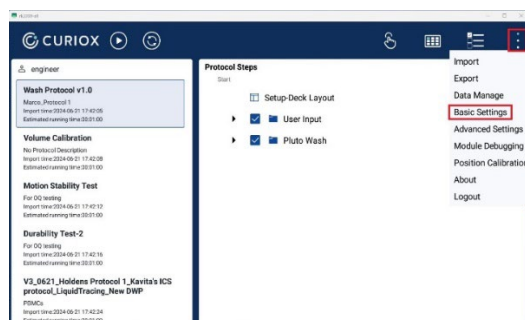

2. In the **Module Debugging** page, select **Fixed 8-channel** in the left list and touch the **Load Tip** button.

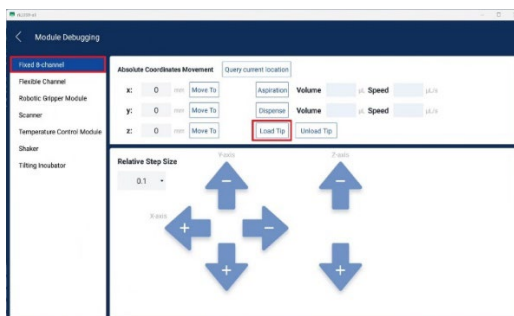

3. Return to the previous page and touch the **Position Calibration** item.

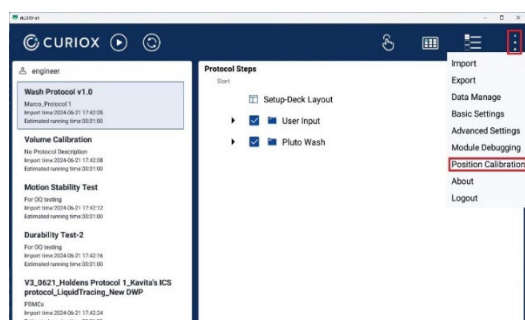

4. Touch Choose Worktable and select Calibration Worktable.

Module Selection

The Pluto LT Workstation has 3 modules that require position calibration. Before proceeding with calibration, select the module that requires calibration and proceed to the next step.

Caution It is important that the 8-channel pipette calibration is completed first. After which the remaining modules can be calibrated.

8-Channel Pipette Selection

1. Touch and select **Instrument**.

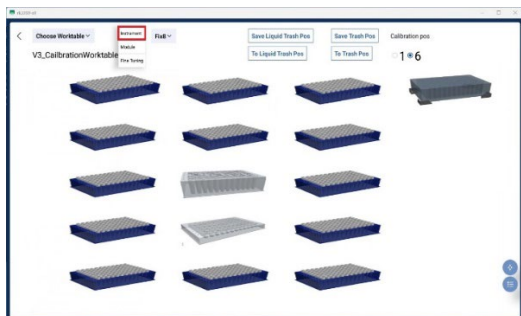

2. Touch the item below and select **Fix8**.



Single Channel Pipette Selection

2.2.1. Tap the item below and select **Module**.



2.2.2. Tap the item below and select **Single Channel**.



Gripper Selection

2.3.1. Tap the item below and select **Module**.



2.3.2. Tap the item below and select **Gripper**.

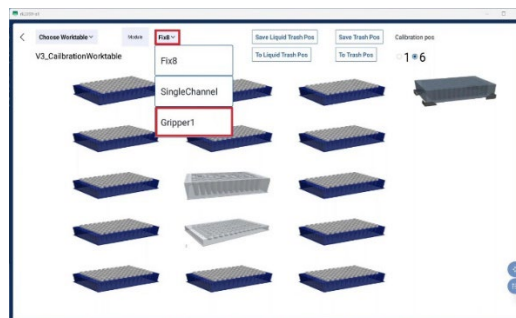

Position Alignment

Each module has a different calibration method.

Module	Calibration Position	Description
8-Channel Pipette	All Positions	
Single Channel Pipette	D3 Position	Only need to calibrate the position of D3 and the remaining positions will be automatically calculated.
Gripper	D2 Position	Only need to calibrate the position of D2 and the remaining positions will be automatically calculated.

Position Alignment—8-Channel Pipette

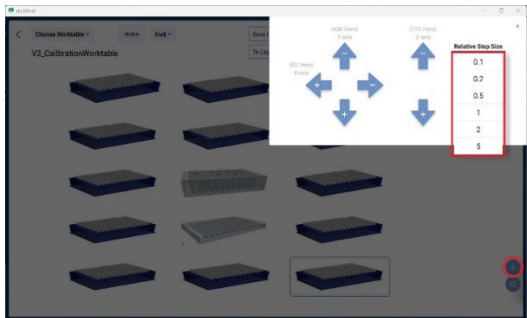
<p>1. Install the fixture at the location where alignment will be performed.</p>	<p>2. Touch the Labware at the location where the fixture is installed and touch the To Position button.</p> 
<p>3. When you touch To Position, the selected module will come near the position of the fixture as shown in the picture below.</p>	<p>4. Touch the Navigator icon and Select the Step length to move each time you touch the button.</p> 
<p>5. Align the Position by touching the X, Y, and Z axis arrows.</p>	

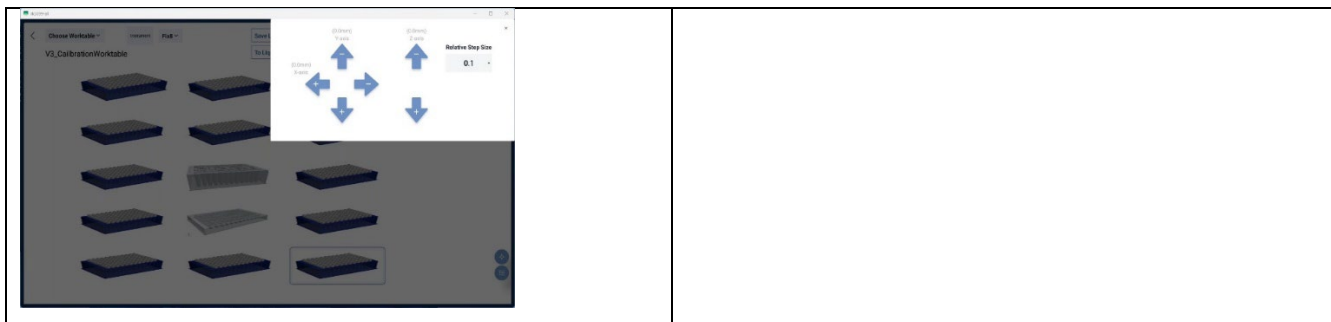

Position Alignment—Single Channel Pipette

The single channel alignment is the same as 8 Channel alignment, but **only the D3 Position needs to be aligned.**

Position Alignment--Gripper

The gripper only needs to be aligned at the **D2 Position.**

1. Adjust the X-axis so that the black screw attached under the gripper is located in the center of column 6 of the plate.



2. Adjust the Y axis so that the distance between the plate and the **gripper tongs is constant.** It doesn't have to be very accurate.

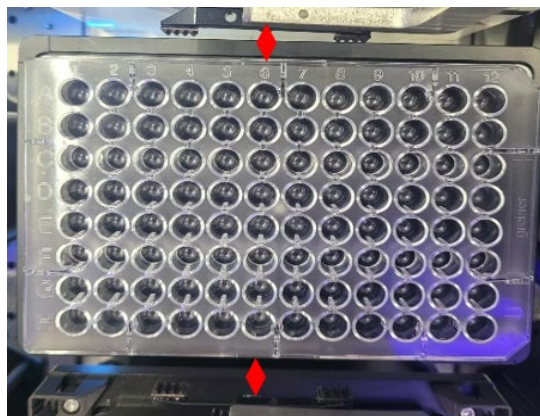

3. Adjust the Z axis so that the black screw on the tongs is at the surface of the plate.

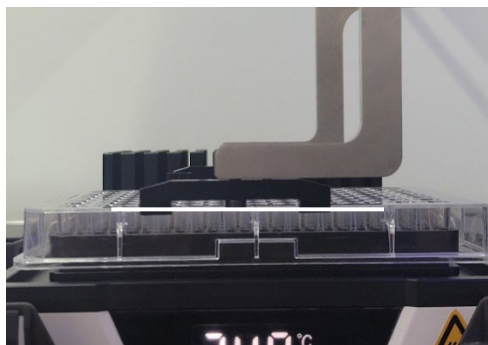

4. After finishing the X, Y and Z alignment, Press the **Save Position** button to save the position values.



Appendix C: Acknowledgement of Decontamination

Acknowledgement of Decontamination Form

Decontamination is required prior to the PLUTO LT Workstation being returned to Curiox Biosystems (i.e., for servicing, maintenance, etc.). You are required to fill out this form to acknowledge that decontamination has been conducted on the instrument. Failure to do so may result in the return of the instrument to your address for decontamination.

PRODUCT SERIAL NO.	
CONTACT INFORMATION	
Dr./Mr./Mrs./Ms. (Please circle accordingly)	JOB TITLE
NAME	EMAIL ADDRESS
COMPANY	PHONE NUMBER
DECONTAMINATION INFORMATION	
DECONTAMINATION METHOD	
DECONTAMINATION DATE	
ACKNOWLEDGEMENT	
<p>I hereby acknowledge that this piece of equipment has been decontaminated and sealed in accordance to the procedure recommended in this manual prior to shipment to Curiox Biosystems. To the best of my knowledge, the equipment is safe to handle by the receiving personnel.</p>	
Name	
<hr/>	
Signature and Date	
<hr/>	

Appendix D: Purchase Information and Feedback

Purchase Information and Feedback Form

PURCHASE INFORMATION	
PRODUCT SERIAL NO.	
PURCHASED BY	PURCHASED FROM
COMPANY	DISTRIBUTOR
ADDRESS	DATE OF PURCHASE
PHONE	DATE OF DELIVERY
FAX	
CONTACT INFORMATION	
Dr./Mr./Mrs./Ms.	JOB TITLE
NAME	EMAIL ADDRESS

FEEDBACK (PLEASE CHECK/COMMENT ACCORDINGLY)					
	Excellent	Good	Average	Poor	Comments
User Guide					
Ease of Use					
Reliability					
Operating Costs					
Overall Experience					

If you have any other comments/suggestions about the PLUTO LT Workstation, please let us know below.

All trademarks are the property of Curiox Biosystems, Inc. unless otherwise specified.